



V16 Heater Shaker



V16 Shaker Break Down

Content:

- (1) diagram of duster:
- (2) duster parts:
- (3) Powder box part:
- (4) Beater bar / scale / vacuum cylinder:
- (5) Threading part:
- (6) Base part:
- (7) Back of Shaker:
- (8) Front heating part :
- (9) Main interface part ;
- (10) Monitoring interface part :
- (11) Parameter setting part:

(1) diagram of duster:



Voltage Spec: 208V-220V 30 amp Single phase
Do not exceed 220V

(2) diagrams of duster:

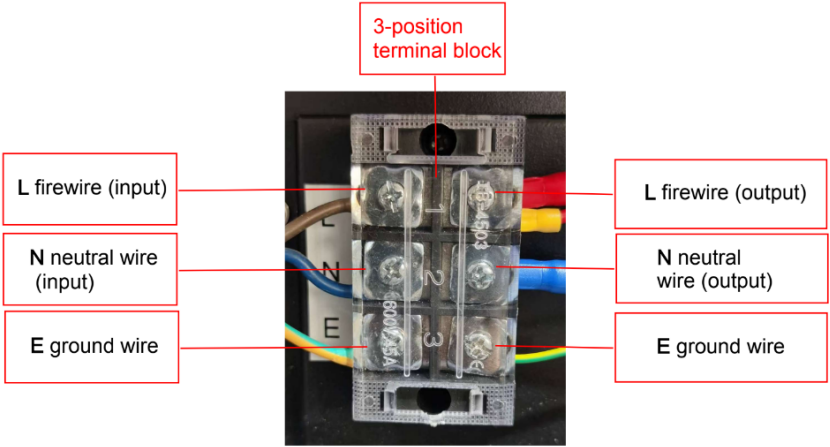
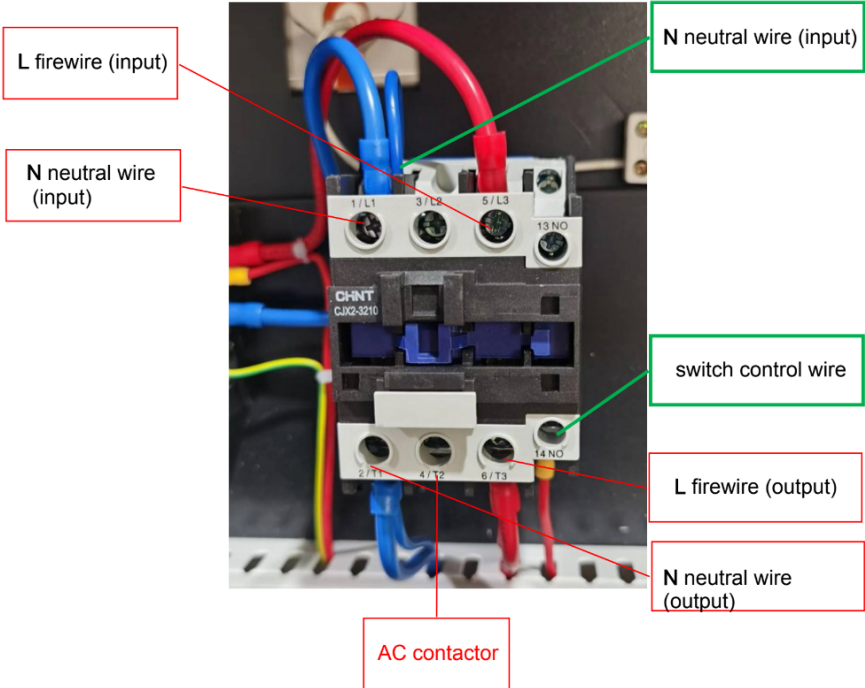
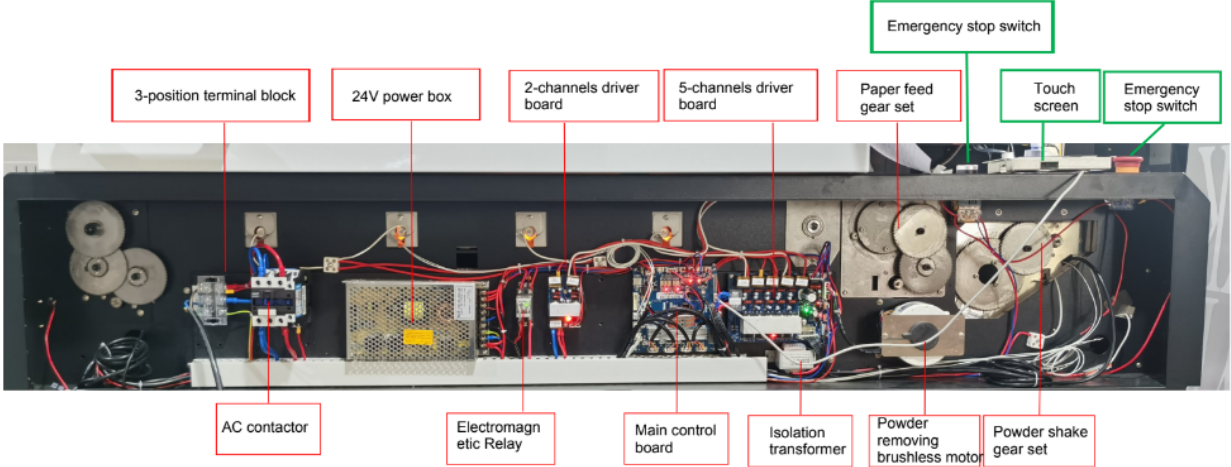

208-220v single phase 30 amp.

(2-2) diagrams of duster:

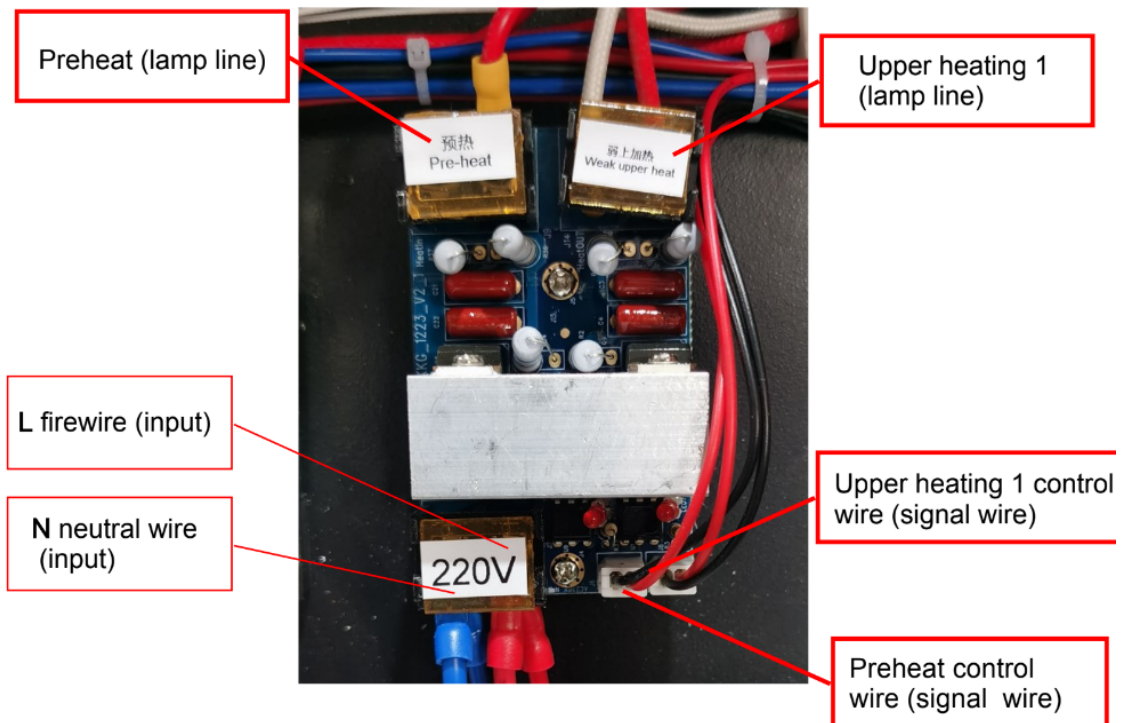
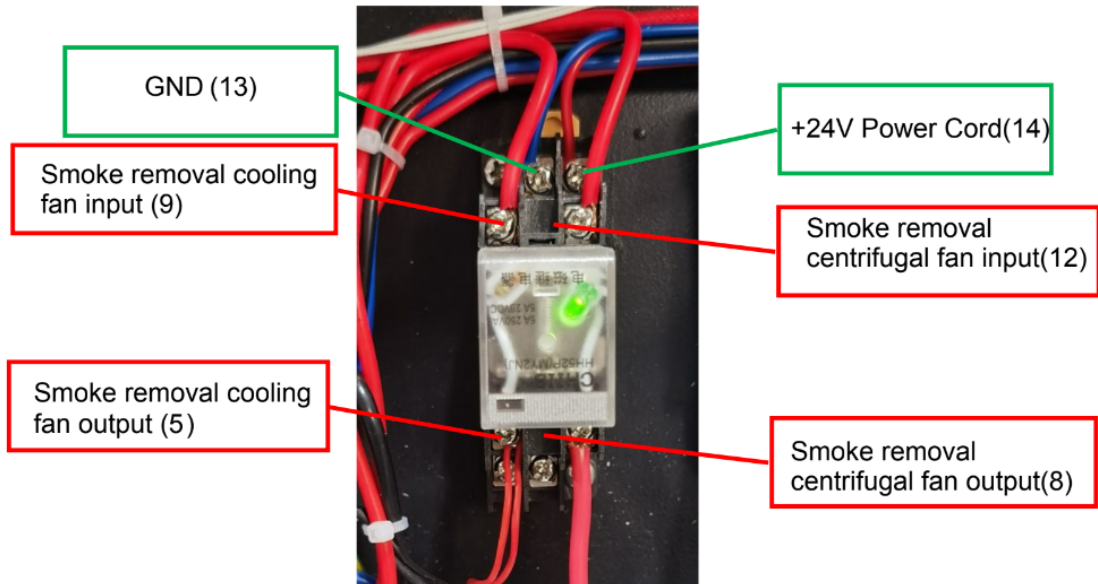

(2-3) diagrams of duster:

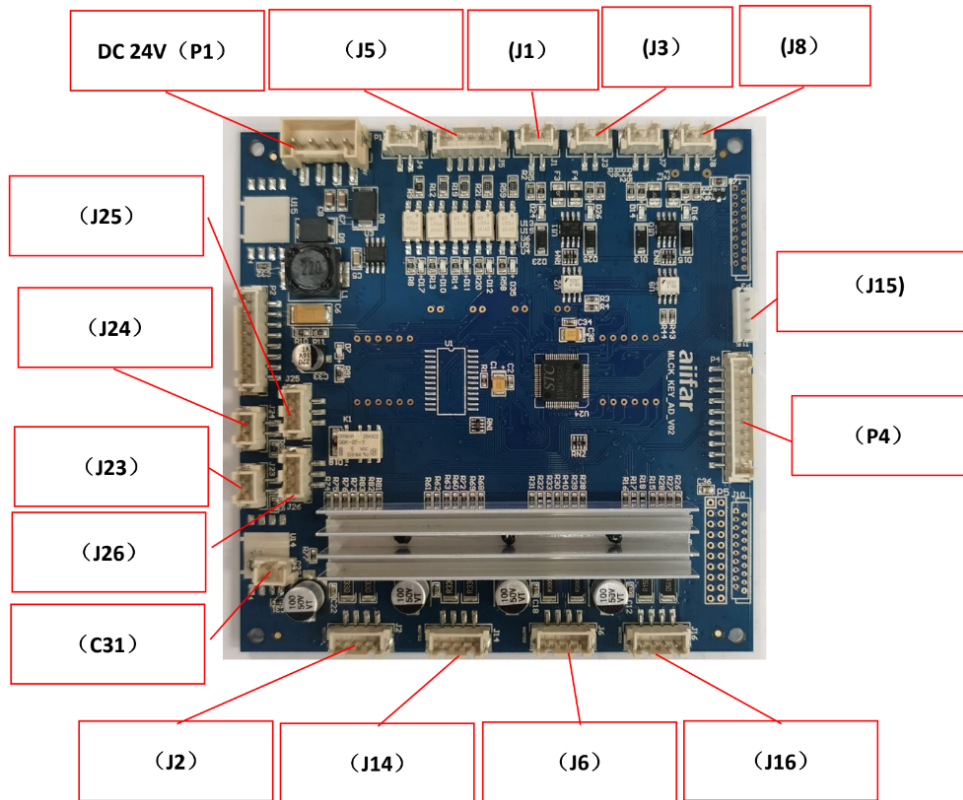

P1	DC24V	J5	Input sensor
J1	Upper heating control wire	J3	Smoke removal style effect control switch wire
J8	Preheat	J25	Tension take-up reel sensor
J24	Platform temperature control	J23	Powder shake box temperature control
J26	Powder box sensor	C31	Preheat temperature control
J15	Show line	P4	Main board control wire
J2	Routing suction roller	J14	Take-up reel control
J6	Conveyor belt	J16	Powder shake motor

(2-4) diagrams of duster:

P1	1	+24V	
	2	+24V	
	3	GND	
	4	GND	

J15	1	24V	
	2	GND	
	3	Null	
	4	Null	
	5	Input sensor signal	

J1 ,J3,J7 ,J8	1	+24V signal output	
	2	GND	

J24,J23, C31	1	GND	
	2	Temperature sensing signal input	

J25,J26	1	5V	
	2	Temperature sensing signal input	
		GND	

J2,J14,J 6,J16	1	A+	
	2	A-	
	3	B+	
	4	B-	

(2-5) diagrams of duster:

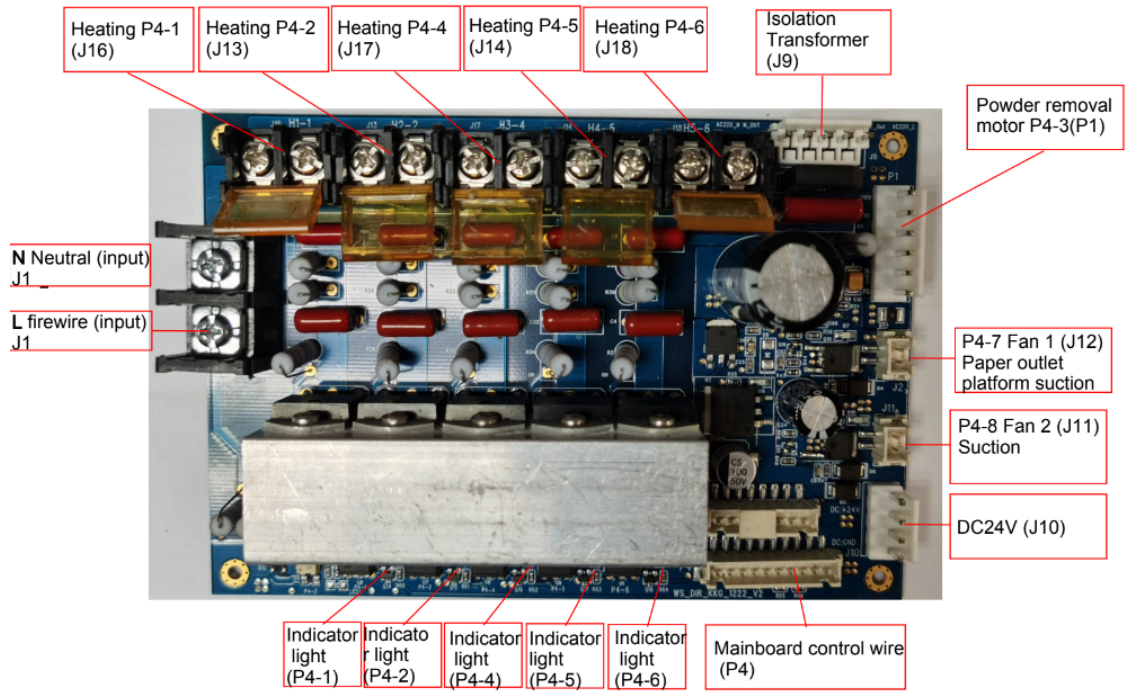

(3) Powder box part:

1. Powder chute

Keep the powder trough dry and clean, and avoid moisture to prevent powder from coagulating and jamming, to keep automatic mode engaged power level on MAIN screen must stay above 70 - To calibrate screen check out our Stsinks youtube channel for video instruction



(4) **Beater Bar / Scale / Vacuum cylinder:**

1. Vacuum Cylinder
2. convey belt / heater
3. high frequency powder removal system / Beater bar / Scale

Keep the powder trough dry and clean, and avoid moisture to prevent powder from coagulating and jamming.

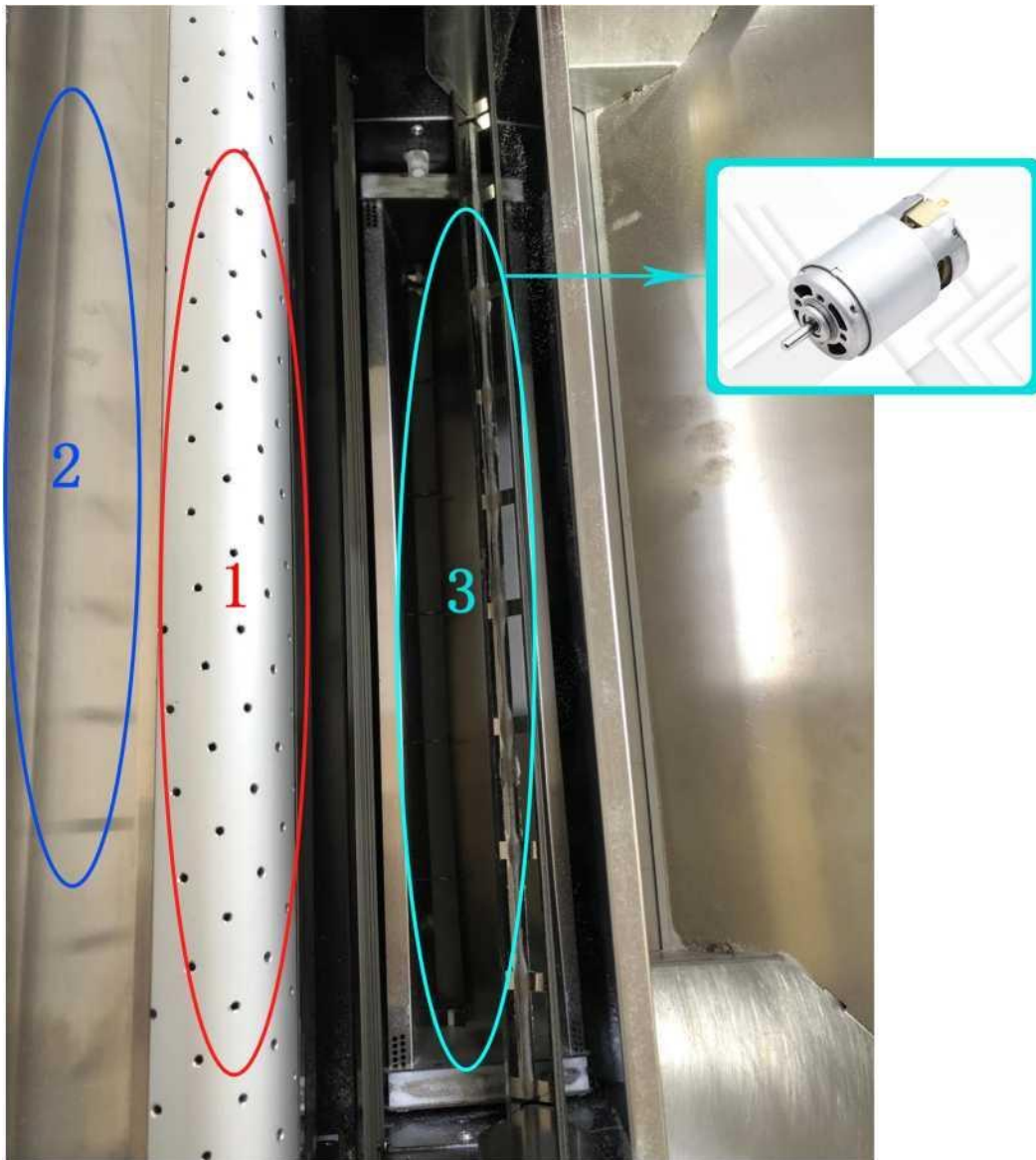

(5) Threading part:

1. Under the tank, is the area you slide the substrate through, to thread it through the heater shaker in order to start the automated process (video on stinks youtube channel)

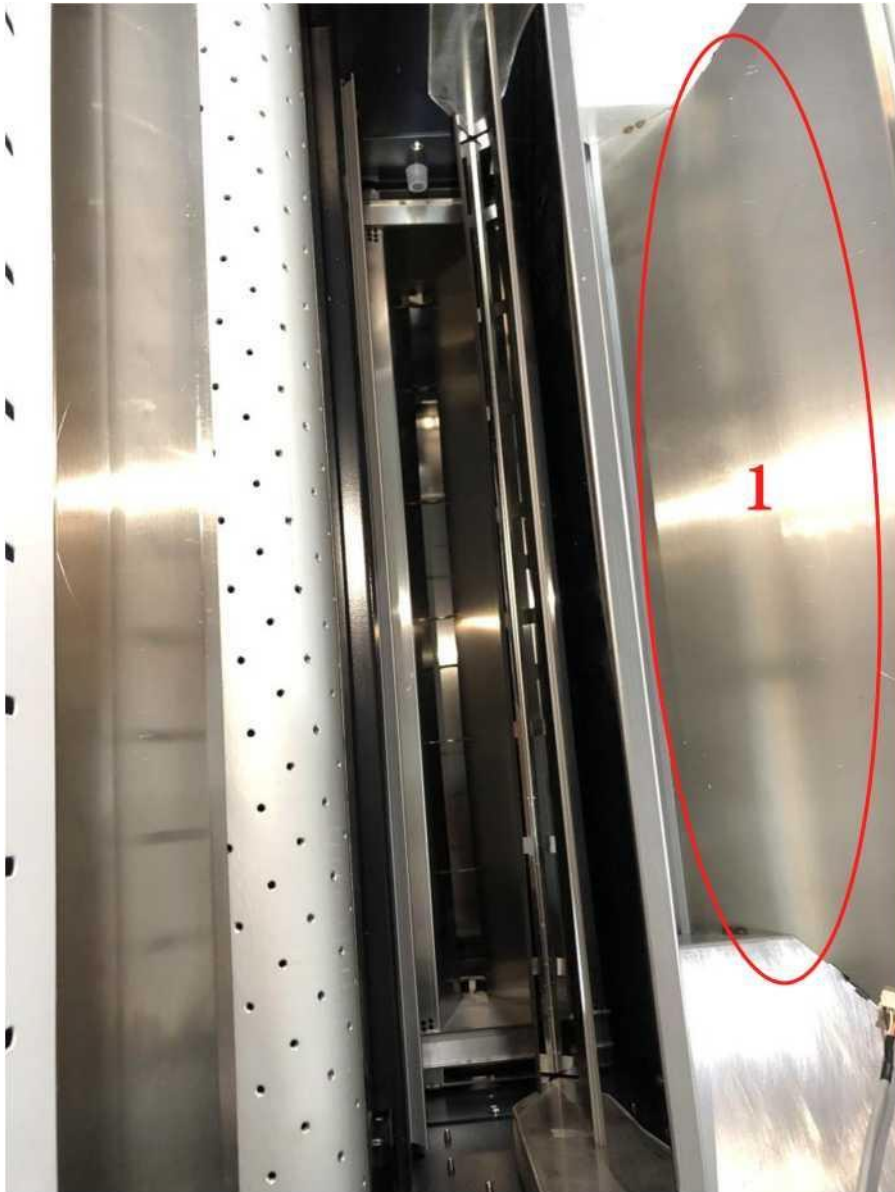

(6)Base part:

1. Blower / Vacuum roller suction motor



(7) Back of shaker:

1. Oven
2. Filter side unit
3. Conveyor belt / under heat elements
4. Cooling fans / Suction zone
5. Take up reel / torque bar



(8) Front heating:

1. Fan assembly
2. Preheat platen
3. Substrate Sensor
4. Powder recycle bay
5. Emergency shut off switch

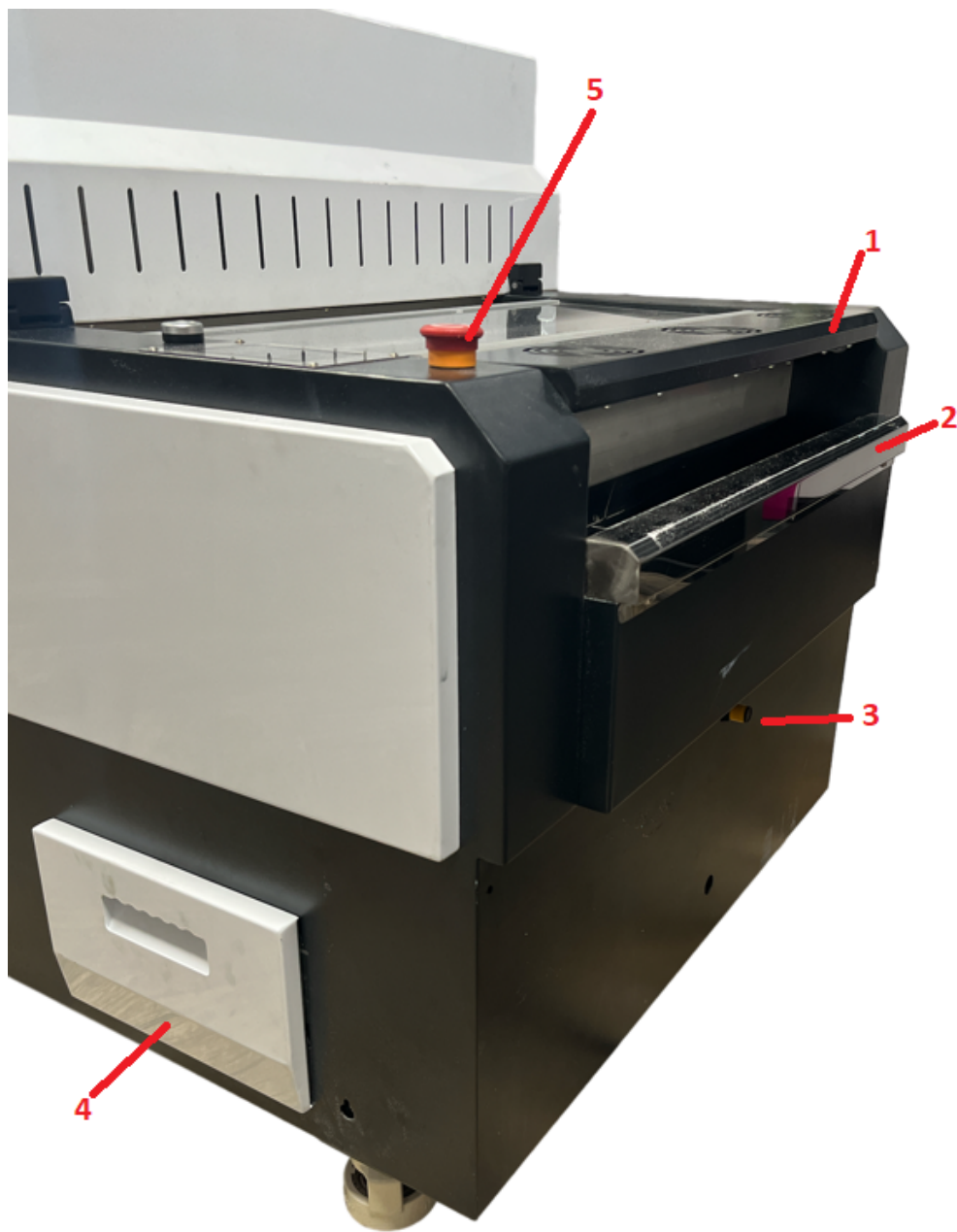

(9) **Main interface part:**

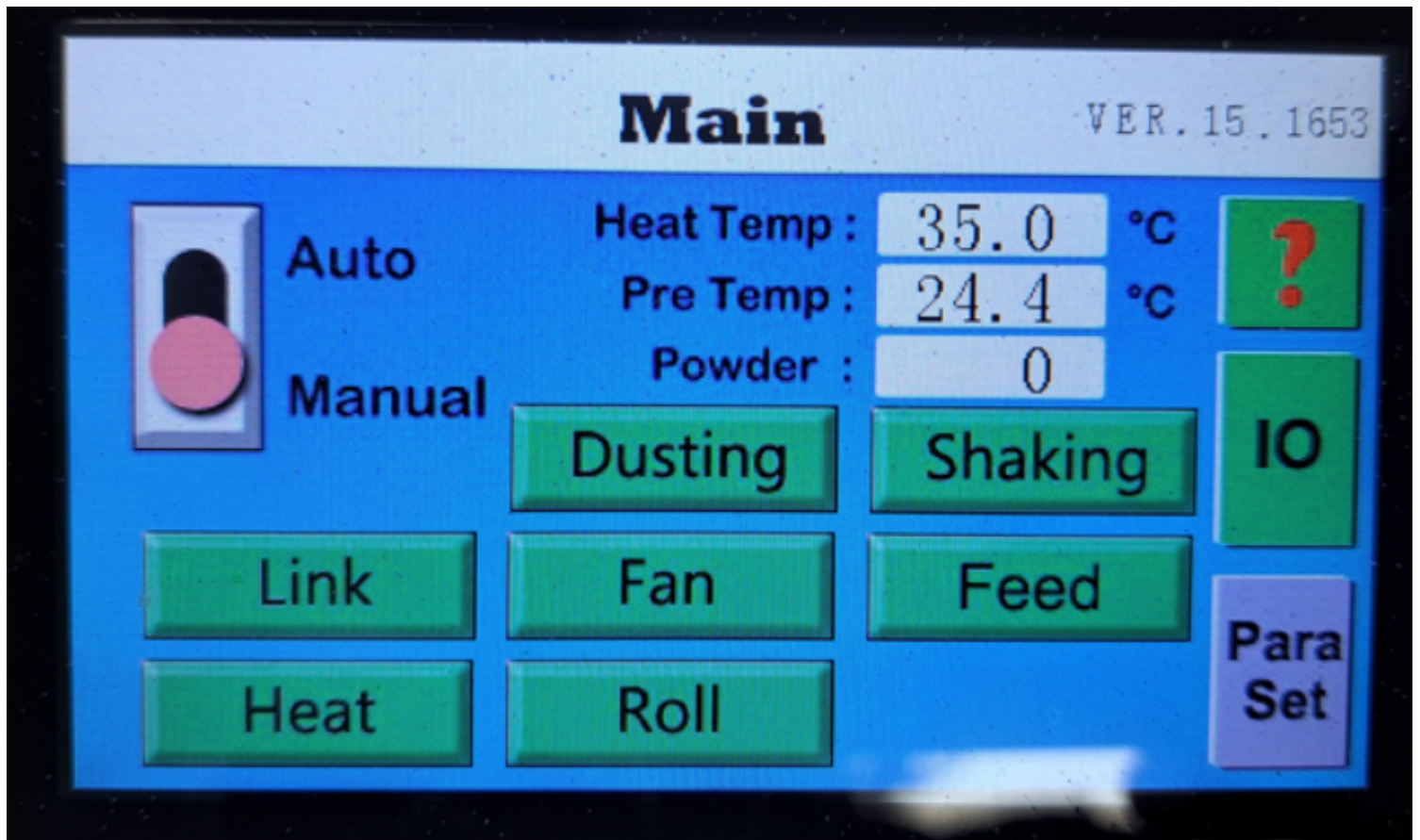

Heat temp: The set temperature from the Para set page

Pre Temp: This is the front heat platen temp

Heat: On and off switch for the heating bay

Dusting: The bay that holds the powders on and off switch (when in manual this will drop powder till turned off)

Shaking: This controls the beater bar that helps remove excess powder from the film

Feed: This moves the Belt

Fan: the suction of the vacuum cylinder / as well as movement of the cylinder

Roll: This is for the take up roller on the back (to calibrate the take up roller, check out our youtube page)

Para set: where to adjust settings

IO: The spot of troubleshoot issues if they may arise, or to see if something is working properly.

AUTO / MANUAL mode

in Manual mode, no sensors are used / or scale

in Auto mode, it requires the power / sensor to see substrate in order for the process to work

(10) Monitoring interface part

X1—Film in : Reads if the film is being read

X3— Film collect: Torque Bar

X4— Bepowder: Reads if it has enough powder on scale

Y0— shaking powder: Beater bar is on or off

Y1—belt: Belt movement

Y15—bottom heat: Pre-Heat element

Y10—fan: Vacuum cylinder is on or off

Y7—link: Link

Y11—Dry Powder: Out of powder

Y12—Roll: Take-up Reel

Y3—Dusting: When dispensing powder

Y17—Drying:

Y13 — Heat: Heating element is on or off

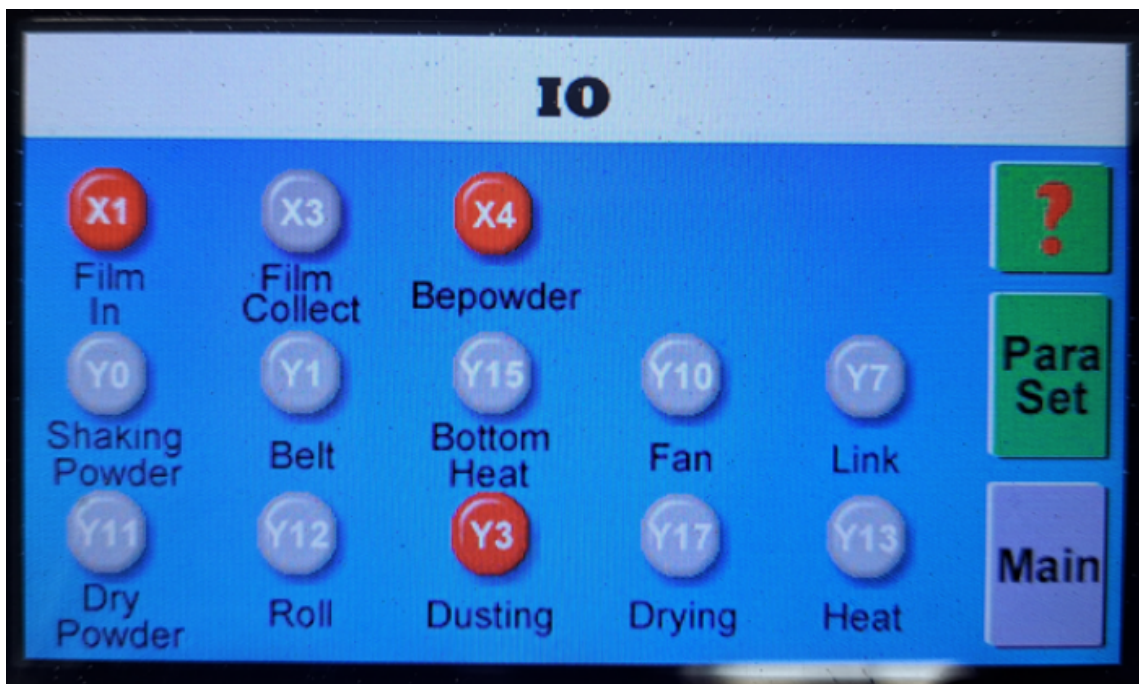

(11) Parameter setting part:

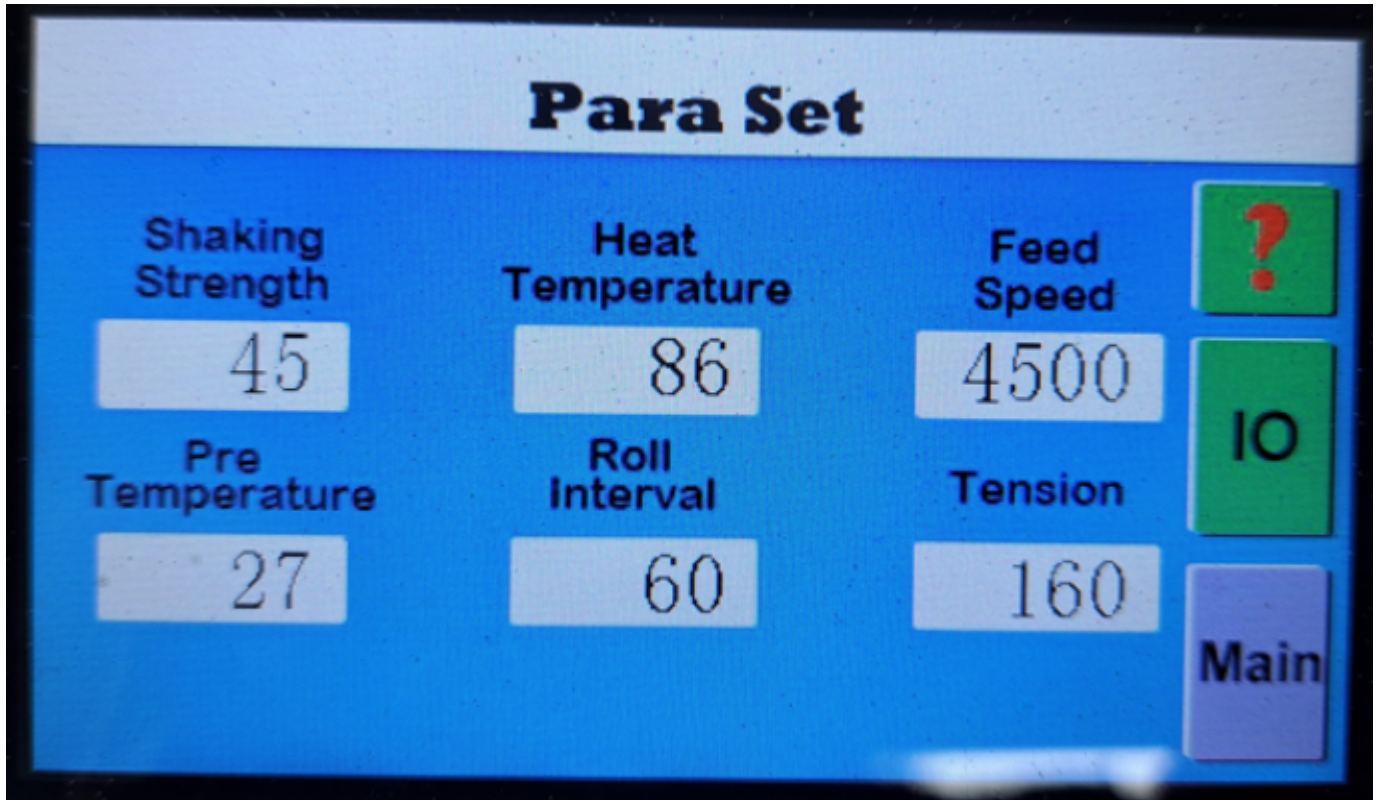

Shaking strength: The beater bars rotations

Heat Temperature: The oven heating temperature

Feed Speed: The belt / Vacuum speed

Pre Temp: The Pre heat platen temp / where you feed the substrate into

Roll Interval: The Take-up roller at the interval control

Tension: Take-up roller tension